

PAC 2010 SH

EN

OPERATING MANUAL
LOCAL AIR CONDITIONER



Table of contents

Notes regarding the operating manual..... 2

Safety 2

Information about the device..... 5

Transport and storage..... 6

Assembly and installation..... 6

Operation 9

Errors and faults..... 11

Maintenance 13

Technical annex..... 16

Disposal 19

Notes regarding the operating manual

Symbols



Danger

This symbol indicates dangers to the life and health of persons due to extremely flammable gas.



Warning of electrical voltage

This symbol indicates dangers to the life and health of persons due to electrical voltage.



Warning

This signal word indicates a hazard with an average risk level which, if not avoided, can result in serious injury or death.



Caution

This signal word indicates a hazard with a low risk level which, if not avoided, can result in minor or moderate injury.

Note

This signal word indicates important information (e.g. material damage), but does not indicate hazards.



Info

Information marked with this symbol helps you to carry out your tasks quickly and safely.



Follow the manual

Information marked with this symbol indicates that the operating manual must be observed.

You can download the current version of the operating manual and the EU declaration of conformity via the following link:

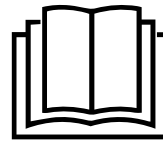

PAC 2010 SH

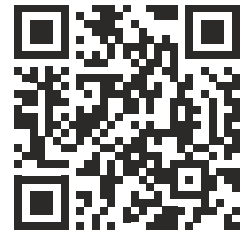

<https://hub.trotec.com/?id=43245>

Safety

Read this manual carefully before starting or using the device. Always store the manual in the immediate vicinity of the device or its site of use!



Warning

Read all safety warnings and all instructions.

Failure to follow the warnings and instructions may result in electric shock, fire and / or serious injury.

Save all warnings and instructions for future reference.

This appliance can be used by children aged from 8 years and above and persons with reduced physical, sensory or mental capabilities or lack of experience and knowledge if they have been given supervision or instruction concerning use of the appliance in a safe way and understand the hazards involved.

Children shall not play with the appliance. Cleaning and user maintenance shall not be made by children without supervision.

- Do not use the device in potentially explosive rooms.
- Do not use the device in aggressive atmosphere.
- Set the device up in an upright and stable position.
- Let the device dry out after a wet clean. Do not operate it when wet.
- Do not use the device with wet or damp hands.
- Do not expose the device to directly squirting water.
- Never insert any objects or limbs into the device.
- Do not cover or transport the device during operation.
- Do not sit on the device.
- This appliance is not a toy! Keep away from children and animals. Do not leave the device unattended during operation.
- Check accessories and connection parts for possible damage prior to every use of the device. Do not use any defective devices or device parts.

- Ensure that all electric cables outside of the device are protected from damage (e.g. caused by animals). Never use the device if electric cables or the power connection are damaged!
- The electrical connection must correspond to the specifications in chapter Technical data.
- Insert the mains plug into a properly secured mains socket.
- Observe the technical data when selecting extensions to the power cable. Completely unroll the extension cable. Avoid electrical overload.
- Before carrying out maintenance, care or repair work on the device, remove the mains plug from the mains socket. Hold onto the mains plug while doing so.
- Switch the device off and disconnect the power cable from the mains socket when the device is not in use.
- Do not under any circumstances use the device if you detect damages on the mains plug or power cable. If the supply cord is damaged, it must be replaced by the manufacturer, its service agent or similarly qualified persons in order to avoid a hazard. Defective power cables pose a serious health risk!
- When positioning the device, observe the minimum distances from walls and other objects as well as the storage and operating conditions specified in the Technical data chapter.
- Make sure that the air inlet and outlet are not obstructed.
- Do not remove any safety signs, stickers or labels from the device. Keep all safety signs, stickers and labels in legible condition.
- Make sure that the suction side is kept free of dirt and loose objects.
- Only transport the device in an upright position with an emptied condensation tray or drain hose.
- Discharge the collected condensate before transport and storage. Do not drink it. Health hazard!
- Only install, operate and store the device PAC 2010 SH in a room measuring more than 6 m².
- Store the device in a way that no mechanical damage can occur.
- Please note that the connected ducts must not contain any sources of ignition.
- R290 is a refrigerant that complies with European environmental regulations. No part of the cooling circuit may be perforated.
- Do not drill through or burn.
- Do not use any means other than those recommended by the manufacturer for accelerating the defrosting process.
- Every person working with or at the refrigerant circuit must be able to provide a certificate of qualification issued by a body accredited by the industry, demonstrating their competence in the safe use of refrigerants based on a procedure well-known in the industry.
- Service work may only be carried out in accordance with the manufacturer's specifications. If maintenance and repair work require the support of additional persons, the person trained in handling flammable refrigerants shall continuously supervise the work carried out.
- Unventilated rooms, in which the device is installed, operated or stored, must be built in a way to ensure that potentially leaking refrigerant cannot accumulate. This serves to avoid fire or explosion hazards resulting from an ignition of the refrigerant by an electric furnace, cooking stove or another ignition source.
- The entire refrigerant circuit is a maintenance-free, hermetically sealed system and may only be maintained or repaired by specialist companies for cooling and air-conditioning or by Trotec.

Intended use

Only use the device for cooling, ventilating, dehumidifying and heating indoor air whilst adhering to the technical data.

Improper use

- Do not place the device on wet or flooded ground.
- Do not place any objects, e.g. clothing, on the device.
- Do not use the device outdoors.
- Any unauthorised modifications, such as alterations or structural changes to the device, are forbidden.
- Any operation other than as described in this manual is prohibited. Non-observance renders all claims for liability and guarantee null and void.



Safety warnings for air conditioners filled with R290

- Only position the device in rooms where potentially leaking refrigerant cannot accumulate.
- Only position the device in rooms where there is no permanent source of ignition (e.g. open flames, an active gas appliance or an electric heater).
- Please note that the refrigerant is odourless.
- Only install the device in compliance with the national installation regulations.
- Observe the national gas regulations.

Personnel qualifications

People who use this device must:

- be aware of the dangers that occur when working with electric devices in damp areas.
- have read and understood the operating manual, especially the Safety chapter.

Maintenance tasks which require the housing to be opened must only be carried out by specialist companies for cooling and air-conditioning or by Trotec.

Safety signs and labels on the device

Note

Do not remove any safety signs, stickers or labels from the device. Keep all safety signs, stickers and labels in legible condition.

The following safety signs and labels are attached to the device:

PAC 2010 SH

WARNING • WARNUNG • ATTENTION

DE Das Gerät muss in einem Raum mit einer Grundfläche größer als 6 m² aufgestellt, betrieben und gelagert werden.

EN Appliance shall be installed, operated and stored in a room with floor area larger than 6 m².

FR L'appareil doit être installé, utilisé et entreposé dans une pièce avec une surface supérieure à 6 m².

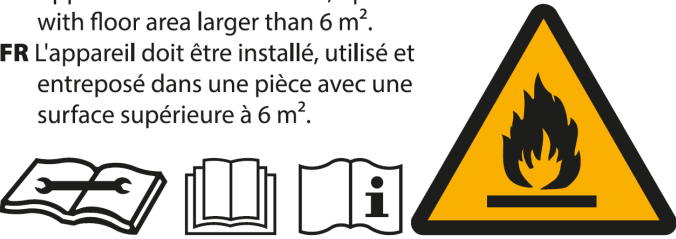

Follow the manual

This symbol indicates that the operating manual must be observed.



Follow the repair manual

Disposal, maintenance and repair work of the refrigerant circuit may only be carried out in accordance with the manufacturer's specifications and by persons having a certificate of qualification. A corresponding repair manual is available from the manufacturer upon request.

Residual risks



Danger

Natural refrigerant propane (R290)!

H220 – Extremely flammable gas.

H280 – Contains gas under pressure; may explode if heated.

P210 – Keep away from heat, sparks, open flames and other ignition sources. No smoking.

P377 – Leaking gas fire: Do not extinguish, unless leak can be stopped safely.

P410+P403 – Protect from sunlight. Store in a well-ventilated place.



Warning of electrical voltage

Work on the electrical components must only be carried out by an authorised specialist company!



Warning of electrical voltage

Before any work on the device, remove the mains plug from the mains socket!

Hold onto the mains plug while pulling the power cable out of the mains socket.



Warning

Dangers can occur at the device when it is used by untrained people in an unprofessional or improper way! Observe the personnel qualifications!



Warning

The device is not a toy and does not belong in the hands of children.



Warning

Risk of suffocation!

Do not leave the packaging lying around. Children may use it as a dangerous toy.

Note

Do not operate the device without an inserted air filter! Without an air filter the inside of the device will be heavily contaminated, which could reduce the dehumidification performance and result in damage to the device.

Behaviour in the event of an emergency

1. Switch off the device.
2. In an emergency, disconnect the device from the mains feed-in: Hold onto the mains plug while pulling the power cable out of the mains socket.
3. Do not reconnect a defective device to the mains.

Information about the device

Device description

The device serves the purpose of cooling the room air. It further filters and dehumidifies the air thus creating an agreeable room climate. Additionally, the device can be used as heater.

The unit cools the room air by withdrawing warmth. The absorbed warmth is emitted to the outside via the exhaust air hose; cooled air is fed to the installation site by means of a fan.

Accumulating condensate drips from the evaporator onto the hot condenser, there it evaporates and then is transported to the outside via the exhaust air hose.

In *ventilation* mode the device provides the opportunity of air circulation without cooling effect.

In *dehumidification* mode moisture is withdrawn from the air.

In *heating* mode the room air is warmed up.

The device operates fully automatically and features a variety of further options. The device can, for instance, be switched on or off automatically with time delay via the timer function.

Operation of the device is possible either via the control panel at the device or via the supplied infrared remote control.

The device was designed for universal and flexible application.

Due to its compact dimensions it can be easily transported and used in all interior spaces.

Device depiction

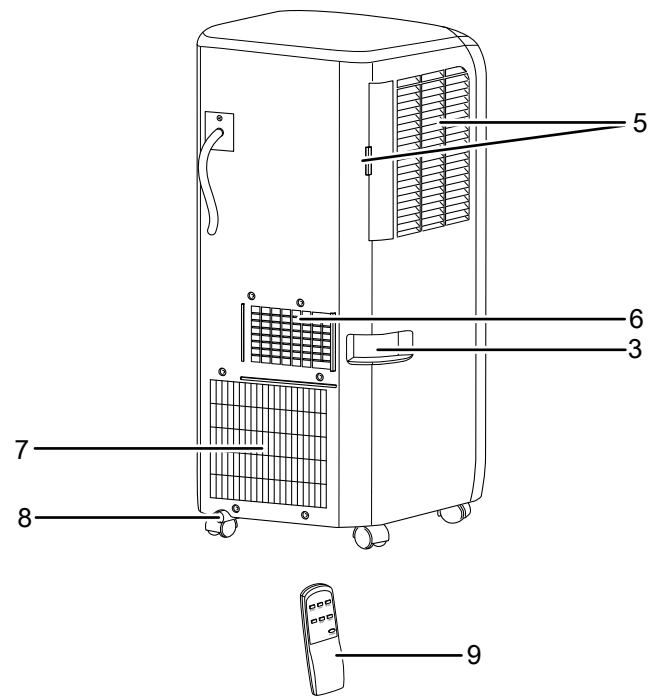
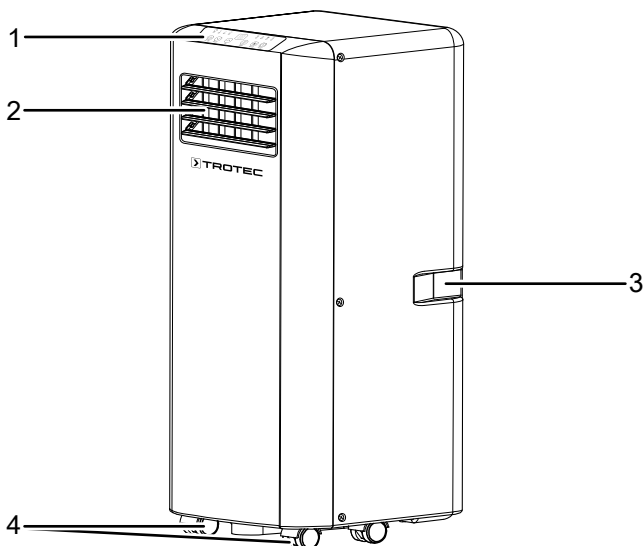

| No. | Designation |
|-----|--|
| 1 | Control panel |
| 2 | Air outlet with adjustable ventilation flaps |
| 3 | Transport handle |
| 4 | Wheels |
| 5 | Air inlet with air filter |
| 6 | Exhaust air hose connection |
| 7 | Air inlet |
| 8 | Condensate outlet with rubber stopper |
| 9 | Remote control |

Transport and storage

Note

If you store or transport the device improperly, the device may be damaged.

Note the information regarding transport and storage of the device.

Transport

To make the device easier to transport, it is fitted with wheels.

To make the device easier to transport, it is fitted with a carry handle.

Before transporting the device, observe the following:

- Switch off the device.
- Hold onto the mains plug while pulling the power cable out of the mains socket.
- Do not use the power cable to drag the device.
- Drain the remaining condensate from the device.
- Only wheel the device on a level and smooth surface.

After transporting the device, observe the following:

- Set up the device in an upright position after transport.
- Leave the device to rest for 12 to 24 hours, so the refrigerant can accumulate within the compressor. Wait 12 to 24 hours before switching the device back on! Acting contrary might lead to compressor damage and a malfunctioning device. If so, any warranty claims will be voided.

Storage

Before storing the device, proceed as follows:

- Drain the remaining condensate from the device.
- Hold onto the mains plug while pulling the power cable out of the mains socket.

When the device is not being used, observe the following storage conditions:

- Only store the device in a room measuring more than 6 m².
- dry and protected from frost and heat
- in an upright position where it is protected from dust and direct sunlight
- with a cover to protect it from invasive dust, if necessary
- Place no further devices or objects on top of the device to prevent it from being damaged.
- Remove batteries from the remote control.

Assembly and installation

Scope of delivery

- 1 x Device
- 1 x Exhaust air hose
- 1 x Hose adapter
- 1 x Hose connector
- 1 x Insert for sliding window
- 1 x Remote control
- 1 x Manual

Unpacking the device

1. Open the cardboard box and take the device out.
2. Completely remove the packaging.
3. Fully unwind the power cable. Make sure that the power cable is not damaged and that you do not damage it during unwinding.

Start-up

When positioning the device, observe the minimum distance from walls or other objects as described in the Technical data chapter.

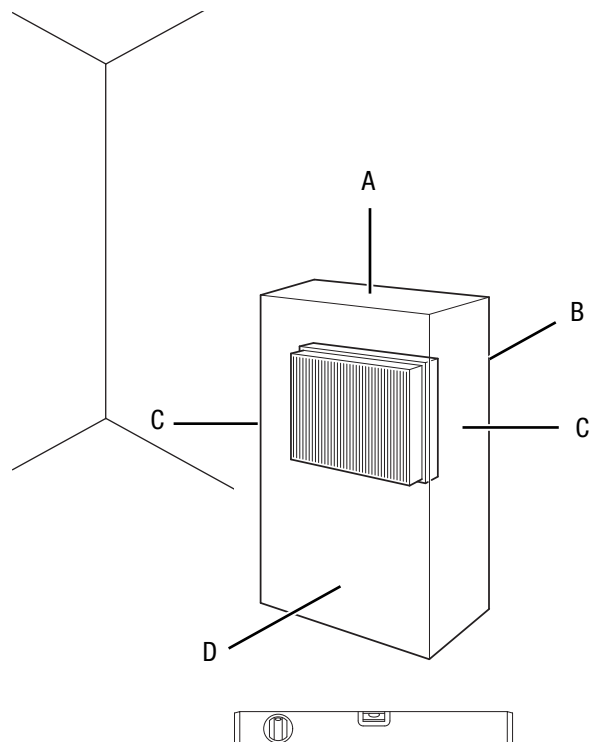

- Before restarting the device, check the condition of the power cable. If there are doubts as to the sound condition, contact the customer service.
- Only position the device in rooms where potentially leaking refrigerant cannot accumulate.

- Only position the device in rooms where there is no permanent source of ignition (e.g. open flames, an active gas appliance or an electric heater).
- Set the device up in an upright and stable position.
- Do not create tripping hazards when laying the power cable or other electric cables, especially when positioning the device in the middle of the room. Use cable bridges.
- Make sure that extension cables are unrolled completely.
- Keep air inlets and outlets as well as the exhaust air hose connection free.
- Make sure that no curtains or other objects interfere with the air flow.

Inserting the air filter

Note

Do not operate the device without an inserted air filter! Without an air filter the inside of the device will be heavily contaminated, which could reduce the dehumidification performance and result in damage to the device.

- Make sure that the air filter is installed before switching the device on.

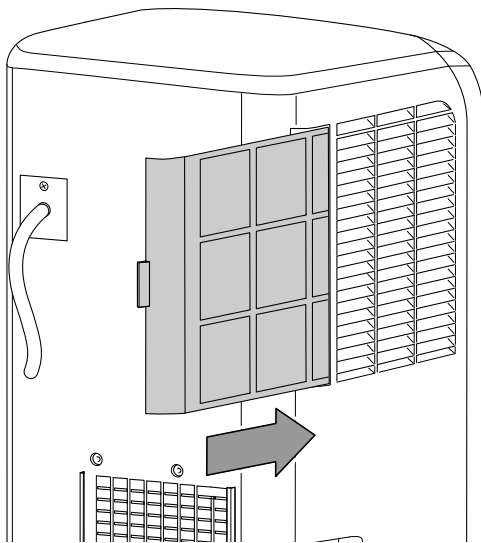

Connecting the exhaust air hose

1. Connect the hose adapter and the hose connector to one end of the exhaust air hose each.

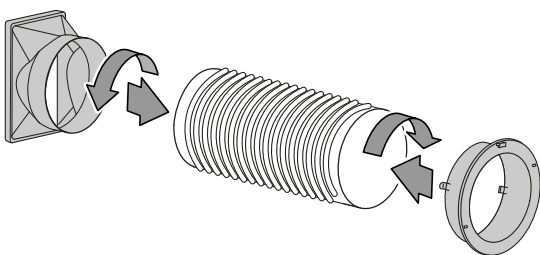

2. Connect the suitable end of the exhaust air hose to the exhaust air hose connection (6) located at the device.

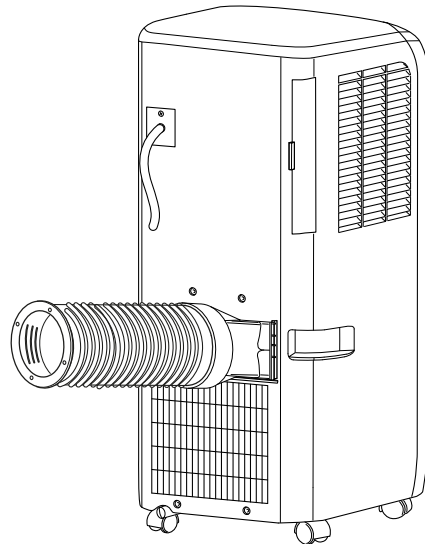
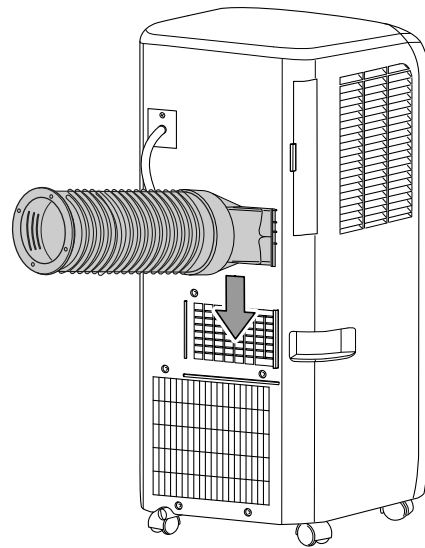

Discharging exhaust air

- The exhaust air coming from the device contains waste heat from the room to be cooled. For this reason it is recommended to discharge the exhaust air to the outside.
- The end of the exhaust air hose can be fed through the open window. If required, secure the open window with the corresponding means, so that the end of the exhaust air hose cannot shift.
- The end of the exhaust air hose can also be hooked into a tilted window. For this purpose, we recommend using a window seal (optional).
- Install the exhaust air hose inclined with the air direction.
- The connected hose must not contain any source of ignition.

How to use the insert

- Affix the insert in the window gap and adjust the length as needed. If required, use the extension piece.
- Connect the flat nozzle to the insert.
- Connect the end of the exhaust air hose to the flat nozzle in the insert.
- Close the window until the insert is held securely.

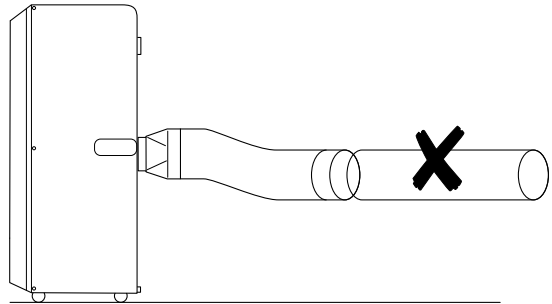
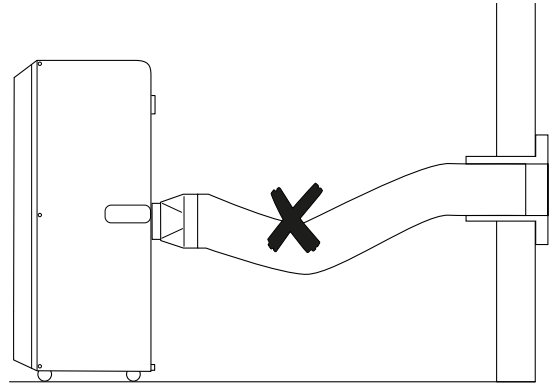
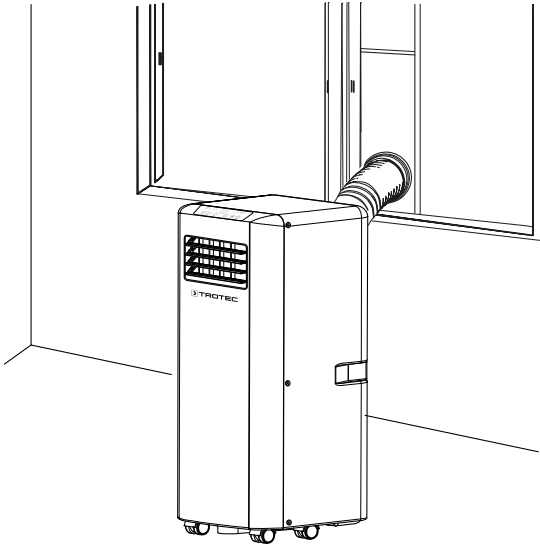

For installing the exhaust air hose please observe the following:

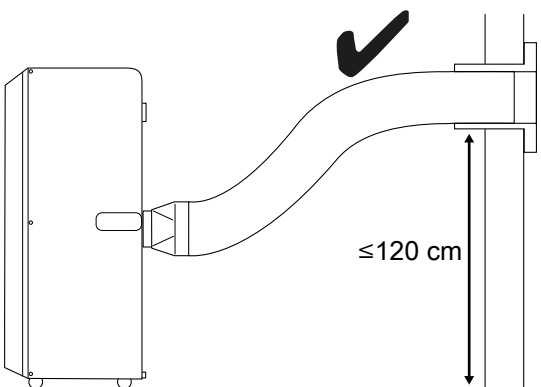
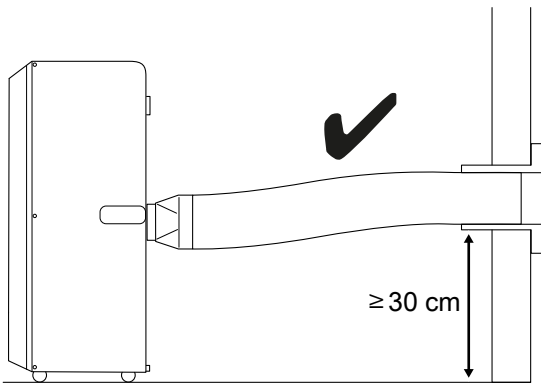

- Avoid kinks and bends in the exhaust air hose, as they would lead to an accumulation of emitted humid air causing the device to overheat and shut down.
- The dimensions of the exhaust air hose were especially made to fit the device. Do not replace or extend the hose, for it could cause a malfunction.

Opening the ventilation flaps

- Prior to switching the device on, open the horizontal ventilation flaps at the air outlet. Adjust the horizontal ventilation flaps to the desired position.

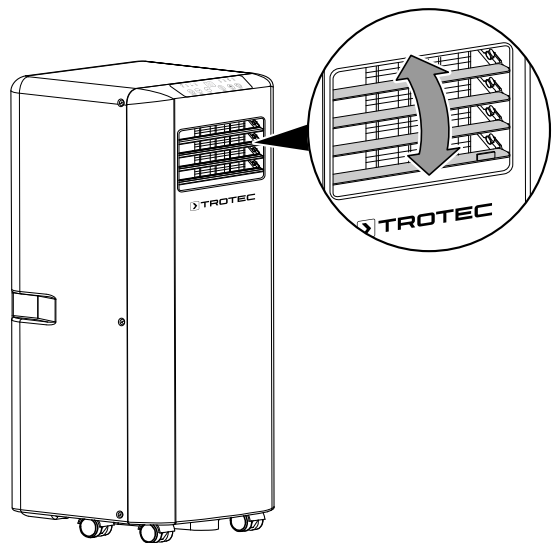

Connecting the power cable

- Insert the mains plug into a properly secured mains socket.

Operation

- Avoid open doors and windows.

Operating elements

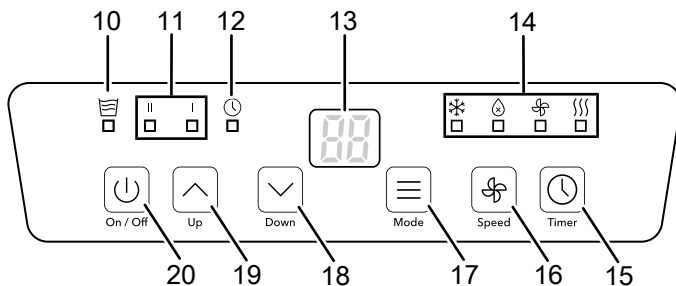

Remote control

All settings of the device can also be made using the remote control included in the scope of delivery.

Insert suitable batteries in the remote control (see chapter Technical annex).

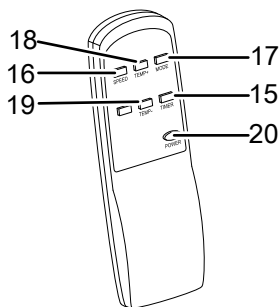

| No. | Designation | Meaning |
|-----|-------------------------|---|
| 10 | Water filling level LED | Empty condensation tray indication |
| 11 | Fan speed LEDs | Fan speed indication: I = low II = high |
| 12 | Timer LED | Illuminated when the timer is activated |
| 13 | Segment display | Indication of the target temperature Indication of the number of hours during timer programming Indication of the error code, see chapter Errors and faults |
| 14 | Operating mode LEDs | Indicates the selected operating mode: ❄ = cooling 💧 = dehumidification 🌀 = ventilation 🔥 = heating |
| 15 | Timer button | Switching the timer functions on and off |
| 16 | Speed button | Setting the fan speed |

| No. | Designation | Meaning |
|-----|-----------------|--|
| 17 | Mode button | Selecting the operating mode: <i>cooling</i> <i>dehumidification</i> <i>ventilation</i> <i>heating</i> |
| 18 | Down button | Setting the target temperature for cooling and heating between 16 °C and 31 °C |
| 19 | Up button | Setting the number of hours for the timer in increments of 1 hour (1 h to 24 h) |
| 20 | On / Off button | Switching the device on and off |



Info

An acoustic signal is emitted each time a setting is activated.

Switching the device on

1. Allow the device to rest for a time.
2. Once you have completely installed the device as described in the Start-up chapter, you can switch it on.
3. Press the *On / Off* button (20).
 - ⇒ The device starts in cooling mode.
 - ⇒ The *cooling* LED is illuminated.
 - ⇒ The *fan speed* LED is illuminated.
4. Select the desired operating mode.

The device switches off automatically when the condensation tray is full. *E2* is displayed on the segment display (13) and the *water filling level* LED (10) is illuminated.

Setting the operating mode

The device has the following operating modes:

- cooling
- dehumidification
- ventilation
- heating

Cooling

In *cooling* mode the room will be cooled down to the desired target temperature.

1. Press the *Mode* button (17) until the *cooling* LED (14) is illuminated.
2. Repeatedly press the *Up* (19) or *Down* (18) button to select the desired target temperature. The temperature can be adjusted in increments of 1 °C in a range between 16 °C and 31 °C.
 - ⇒ The desired target temperature is indicated on the segment display (13).
3. Press the *Speed* button (16) to set the desired fan stage.
 - ⇒ The *fan speed* LED (11) for the desired fan stage will be illuminated.
 - ⇒ The *cooling* LED (14) will be illuminated to indicate *cooling* mode.

Dehumidification

In *dehumidification* mode the humidity level in the room is reduced.

The temperature cannot be adjusted and the fan runs at the lowest speed level.



Info

Remove the exhaust air hose during *dehumidification*, otherwise the performance will be insufficient.

1. Press the *Mode* button (17) until the *dehumidification* LED (14) is illuminated.
 - ⇒ *Dehumidification* mode is selected.
 - ⇒ The temperature and the fan speed (stage I) are preset in this operating mode and cannot be changed.



Info

If the device is operated in a very humid environment, the accumulating condensate must be discharged at regular intervals (see chapter Condensate discharge).

Ventilation



Info

Remove the exhaust air hose during *ventilation*.

In *ventilation* mode the room air is circulated, it will neither be cooled nor dehumidified.

1. Press the *Mode* button (17) until the LED for *ventilation* (14) lights up.
2. Press the *Speed* button (16) to set the desired fan speed.
 - ⇒ The LED for the selected fan speed (11) will be illuminated.

Heating operation

In *heating* mode the room will be heated up to the desired target temperature.

1. Press the *Mode* button (17) until the *heating* LED (14) is illuminated.
 - ⇒ *Heating* mode is selected.
2. Repeatedly press the *Up* (19) or *Down* (18) button to select the desired target temperature. The temperature can be adjusted in increments of 1 °C in a range between 16 °C and 31 °C.
 - ⇒ The desired target temperature is indicated on the segment display (13).
3. Press the *Speed* button (16) to set the desired fan stage.
 - ⇒ The *fan speed* LED (11) for the desired fan stage will be illuminated.
 - ⇒ The *heating* LED (14) will be illuminated to indicate *heating* mode.



Info

After switch-off, the fan keeps running for a brief period during which no settings can be made.

Setting the timer

The timer has two modes of operation:

- automatic switch-on upon expiry of a preset number of hours
- automatic switch-off upon expiry of a preset number of hours

The timer can be programmed in increments of 1 hour (1 h to 24 h).

The function can be set in all operating modes. It can be activated both during operation and in standby mode.

Note

Do not leave the operating device unattended in a freely accessible room with an activated timer.

Automatic switch-on

✓ The device is switched off.

1. Press the *Timer* button (15).
 - ⇒ The *timer* LED (12) is illuminated.
 - ⇒ The number of hours flashes on the segment display (13) for approx. 10 s.
2. Repeatedly press the *Up* (19) or *Down* (18) button to select the desired number of hours until automatic switch-on.
3. Press the *Timer* button (15) to confirm the setting.
 - ⇒ The segment display (13) continuously indicates the number of hours until automatic switch-on.
 - ⇒ After the predefined time, the device switches itself on.
4. In order to delete the setting, press the *Timer* button (15) again.
 - ⇒ The *timer* LED (12) goes out.

Notes regarding automatic switch-on:

- If the device is disconnected from the power supply, all settings for automatic switch-on are deleted.
- Manually switching the device on disables the automatic switch-on function.

Automatic switch-off

✓ The device is switched on.

1. Press the *Timer* button (15).
 - ⇒ The *timer* LED (12) is illuminated.
 - ⇒ The number of hours flashes on the segment display (13) for approx. 10 s.
2. Repeatedly press the *Up* (19) or *Down* (18) button to select the desired number of hours until automatic switch-off.
3. Press the *Timer* button (15) to confirm the setting.
 - ⇒ The segment display (13) continuously indicates the number of hours until automatic switch-off.
 - ⇒ After the predefined time, the device switches itself off.
4. In order to delete the setting, press the *Timer* button (15) again.
 - ⇒ The *timer* LED (12) goes out.

Notes regarding automatic switch-off:

- Pressing the *On / Off* button (20) deactivates the automatic switch-off function.

Automatic defrost

At low ambient temperatures, ice may form at the evaporator. The device will then carry out an automatic defrost.

The compressor switches off and the fan keeps running until defrosting is completed. The duration of the defrost process can vary.

Do not switch the device off during automatic defrost. Do not remove the mains plug from the mains socket.

Shutdown



Warning of electrical voltage

Do not touch the mains plug with wet or damp hands.

- Switch off the device.
- Hold onto the mains plug while pulling the power cable out of the mains socket.
- Empty the condensation tray if necessary.
- If necessary, remove the condensation drain hose and any residual fluid from it.
- Clean the device according to the Maintenance chapter.
- Store the device according to the Storage chapter.

Errors and faults

The device has been checked for proper functioning several times during production. If malfunctions occur nonetheless, check the device according to the following list.

The device does not start:

- Check the power connection.
- Check the power cable and mains plug for damages.
- Check the on-site fusing.
- Observe the operating temperature according to the Technical data chapter.
- The condensation tray may be full. Empty the condensation tray if necessary. The error code *E2* must not be indicated on the segment display and the *water filling level* LED (10) must not be illuminated.
- Wait for 10 minutes before restarting the device. If the device is not starting, have the electricians checked by a specialist company or by Trotec.

The device works with reduced or no cooling capacity:

- Check whether *cooling* mode is selected.
- Check the proper fit of the exhaust air hose. In case of kinks, bends or blockage in the hose, exhaust air cannot be discharged. Clear the way for the exhaust air.
- Check the position of the ventilation flaps. They should be opened to the maximum.
- Check the air filter(s) for dirt. If necessary, clean or replace the air filter(s).
- Check the minimum distance to walls or other objects. Position the device a little more in the room's centre if required.
- Check whether any windows and/or doors of the room are open. If so, close them. One window has to remain open for the exhaust air hose nonetheless.
- Check the temperature setting at the device. Reduce the set temperature if it is higher than the room temperature.

The device is loud or vibrates:

- Check whether the device is set up in a stable and upright position.

Condensate is leaking:

- Check the device for leaks.

The compressor does not start:

- Check whether the overheating protection of the compressor has tripped. Disconnect the device from the mains and let it cool down for approx. 10 minutes before reconnecting it.
- Check whether the ambient temperature equals the target temperature (in *cooling* mode). The compressor will not switch on unless the respective temperature is reached.
- The compressor may start up with a delay of 3 minutes, as it is provided with an internal protection against direct restart.

The device gets very warm, is loud or loses power:

- Check the air inlets and air filters for dirt. Remove external dirt.
- From the outside, check the device for dirt (see chapter Maintenance). If the inside of the device is dirty, have it cleaned by a specialist company for cooling and air-conditioning or by Trotec.

The device does not respond to the infrared remote control:

- Check whether the distance between remote control and device is too large and reduce it if necessary.
- Make sure there are no obstacles, such as furniture or walls, between the device and the remote control. Ensure visual contact between device and remote control.
- Check the charging status of the batteries and change them if required.
- If the batteries have only just been changed, check them for correct polarity and change them if required.

Note

Wait for at least 3 minutes after maintenance and repair work. Only then switch the device back on.

Your device still does not operate correctly after these checks?

Please contact the customer service. If necessary, bring the device to a specialist company for cooling and air-conditioning or to Trotec for repair.

Error codes

The following error messages can be displayed on the segment display (13):

| Error code | Cause | Remedy |
|-------------------|--------------------------------------|--|
| E0 | Error at the room temperature sensor | Disconnect the device briefly from the mains. Should the error still be displayed after the restart, please contact the customer service. |
| E2 | Condensation tray full | Empty the condensation tray. Should the error still be displayed, please contact the customer service. |

Maintenance

Maintenance intervals

| Maintenance and care interval | before every start-up | as needed | at least every 2 weeks | at least every 4 weeks | at least every 6 months | at least annually |
|--|-----------------------|-----------|------------------------|------------------------|-------------------------|-------------------|
| Check the air inlets and outlets for dirt and foreign objects and clean if necessary | X | | | X | | |
| Clean the exterior | | X | | | | X |
| Visually check the inside of the device for dirt | | X | | | | X |
| Check the air filter for dirt and foreign objects and clean or replace if necessary | X | | X | | | |
| Replace the air filter | | | | | X | |
| Check for damage | X | | | | | |
| Check the attachment screws | | X | | | | X |
| Test run | | | | | | X |
| Empty the condensation tray and drain hose | | X | | | | |

Maintenance and care log

Device type:

Device number:

| Maintenance and care interval | 1 | 2 | 3 | 4 | 5 | 6 | 7 | 8 | 9 | 10 | 11 | 12 | 13 | 14 | 15 | 16 |
|---|---|---|---|---|---|---|---|---|---|----|----|----|----|----|----|----|
| Check air inlets and outlets for dirt and foreign objects and clean if necessary | | | | | | | | | | | | | | | | |
| Clean the exterior | | | | | | | | | | | | | | | | |
| Visually check the inside of the device for dirt | | | | | | | | | | | | | | | | |
| Check the air filter for dirt and foreign objects and clean or replace if necessary | | | | | | | | | | | | | | | | |
| Replace the air filter | | | | | | | | | | | | | | | | |
| Check for damage | | | | | | | | | | | | | | | | |
| Check the attachment screws | | | | | | | | | | | | | | | | |
| Test run | | | | | | | | | | | | | | | | |
| Empty the condensation tray and drain hose | | | | | | | | | | | | | | | | |
| Comments | | | | | | | | | | | | | | | | |

| | | | |
|------------------|------------------|------------------|------------------|
| 1. Date: | 2. Date: | 3. Date: | 4. Date: |
| Signature: | Signature: | Signature: | Signature: |
| 5. Date: | 6. Date: | 7. Date: | 8. Date: |
| Signature: | Signature: | Signature: | Signature: |
| 9. Date: | 10. Date: | 11. Date: | 12. Date: |
| Signature: | Signature: | Signature: | Signature: |
| 13. Date: | 14. Date: | 15. Date: | 16. Date: |
| Signature: | Signature: | Signature: | Signature: |

Activities required before starting maintenance



Warning of electrical voltage

Do not touch the mains plug with wet or damp hands.

- Switch the device off.
- Hold onto the mains plug while pulling the power cable out of the mains socket.



Warning of electrical voltage

Tasks which require the housing to be opened must only be carried out by authorised specialist companies or by Trotec.

Refrigerant circuit



Danger

Natural refrigerant propane (R290)!

H220 – Extremely flammable gas.
H280 – Contains gas under pressure; may explode if heated.

P210 – Keep away from heat, sparks, open flames and other ignition sources. No smoking.
P377 – Leaking gas fire: Do not extinguish, unless leak can be stopped safely.
P410+P403 – Protect from sunlight. Store in a well-ventilated place.

- The entire refrigerant circuit is a maintenance-free, hermetically sealed system and may only be maintained or repaired by specialist companies for cooling and air-conditioning or by Trotec.

Safety signs and labels on the device

Check the safety signs and labels attached to the device at regular intervals. Replace illegible safety signs!

Cleaning the housing

Clean the housing with a soft, damp and lint-free cloth. Ensure that no moisture enters the housing. Protect electrical components from moisture. Do not use any aggressive cleaning agents such as cleaning sprays, solvents, alcohol-based or abrasive cleaners to dampen the cloth.

Visual inspection of the inside of the device for dirt

1. Remove the air filter.
2. Use a torch to illuminate the openings of the device.
3. Check the inside of the device for dirt.
4. If you see a thick layer of dust, have the inside of the device cleaned by a specialist company for cooling and air-conditioning or by Trotec.

5. Put the air filter back in.

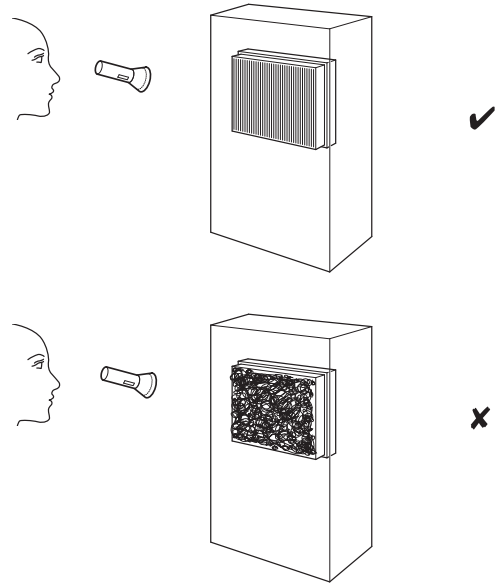

Cleaning the air filter

The air filters have to be cleaned as soon as they are dirty. This is brought to light e.g. by a reduced capacity (see chapter Errors and faults).



Warning

Ensure that the air filters are neither worn nor damaged. The corners and edges of the air filters must not be deformed or rounded. Before reinserting the air filters, make sure that they are undamaged and dry!

1. Remove the air filters from the device.

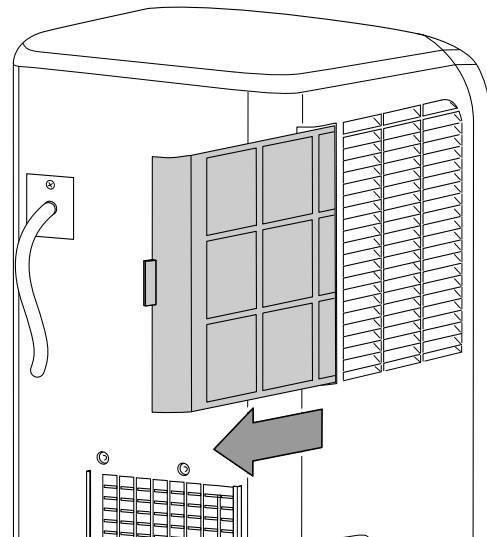

2. Clean the filters using a slightly damp, soft, lint-free cloth. If the filters are heavily contaminated, clean them with warm water mixed with a neutral cleaning agent.
3. Allow the filters to dry completely. Do not put any wet filters into the device!

4. Reinsert the air filters into the device.

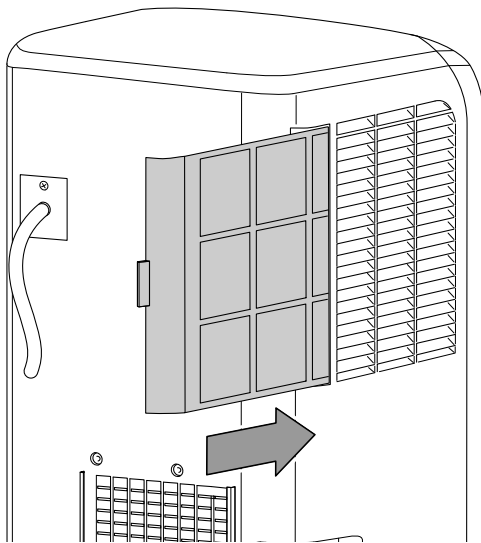

Condensate discharge (manual draining)

In *cooling* and *dehumidification* mode condensate is formed, which is mostly discharged via the exhaust air.

The remaining condensate is collected in a container within the housing. The condensate ought to be drained regularly.

1. Carefully transport or wheel the device to a suitable location for discharging the condensate (e.g. a drain) or position a suitable collection container under the condensate outlet.

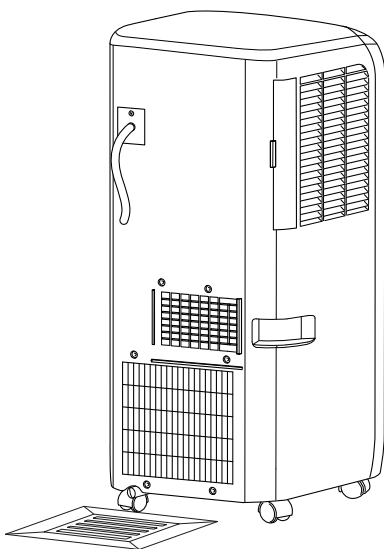

2. Remove the rubber stopper from the condensate outlet.

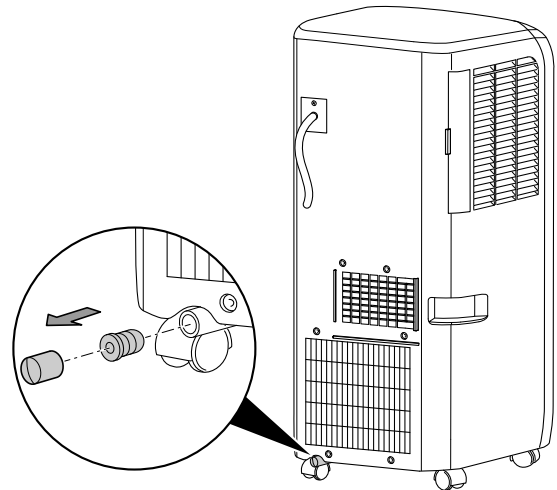

3. Drain the condensate.
4. Reattach the rubber stopper to the condensate outlet. Ensure the tight fit of the rubber stopper, for otherwise there might be uncontrolled water leakage.

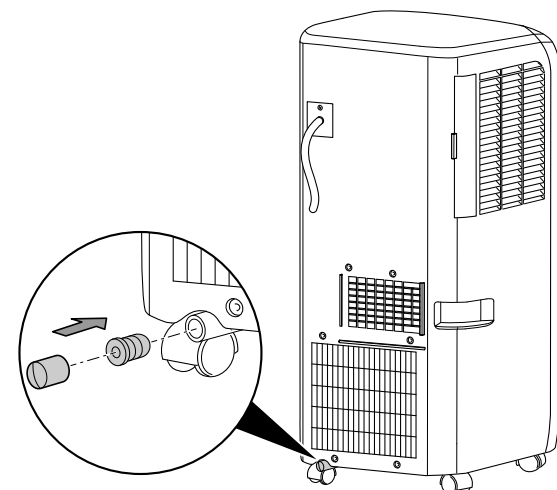

⇒ The error code *E2* is no longer indicated on the segment display (13) and the *water filling level* LED (10) will go out as soon as the condensate has been drained.

Activities required after maintenance

If you want to continue using the device:

- Leave the device to rest for 12 to 24 hours, so the refrigerant can accumulate within the compressor. Wait 12 to 24 hours before switching the device back on! Acting contrary might lead to compressor damage and a malfunctioning device. If so, any warranty claims will be voided.
- Reconnect the device to the mains.

If you do not intend to use the device for a considerable time:

- Store the device according to the Storage chapter.

Technical annex

Technical data

| Model | PAC 2010 SH |
|--|---|
| Cooling capacity | 2.05 kW |
| Heating capacity | 1.8 kW |
| Dehumidification performance | 0.8 l/h |
| Operating temperature | 16 °C to 35 °C |
| Temperature setting range | 16 °C to 31 °C |
| Max. air volume flow | 320 m ³ /h |
| Pressure suction side | 1 MPa |
| Pressure outlet side | 2.6 MPa |
| Mains supply | 220 V – 240 V / 50 Hz |
| Nominal current | 3.5 A |
| Power input (cooling operation) | 785 W |
| Power input (heating operation) | 890 W |
| Sound pressure level at a distance of 1 m | 53 dB(A) |
| Refrigerant | R290 |
| Amount of refrigerant | 140 g |
| GWP factor | 3 |
| CO ₂ equivalent | 0.00042 t |
| Dimensions (length x width x height) | 300 x 320 x 700 mm |
| Minimum distance to walls and other objects: | top (A): 30 cm rear (B): 30 cm sides (C): 30 cm front (D): 30 cm |
| Weight | 19 kg |
| Remote control batteries | Type LR03 / AAA – 1.5 V (2 pcs.) |

Circuit diagram

WIRING DIAGRAM

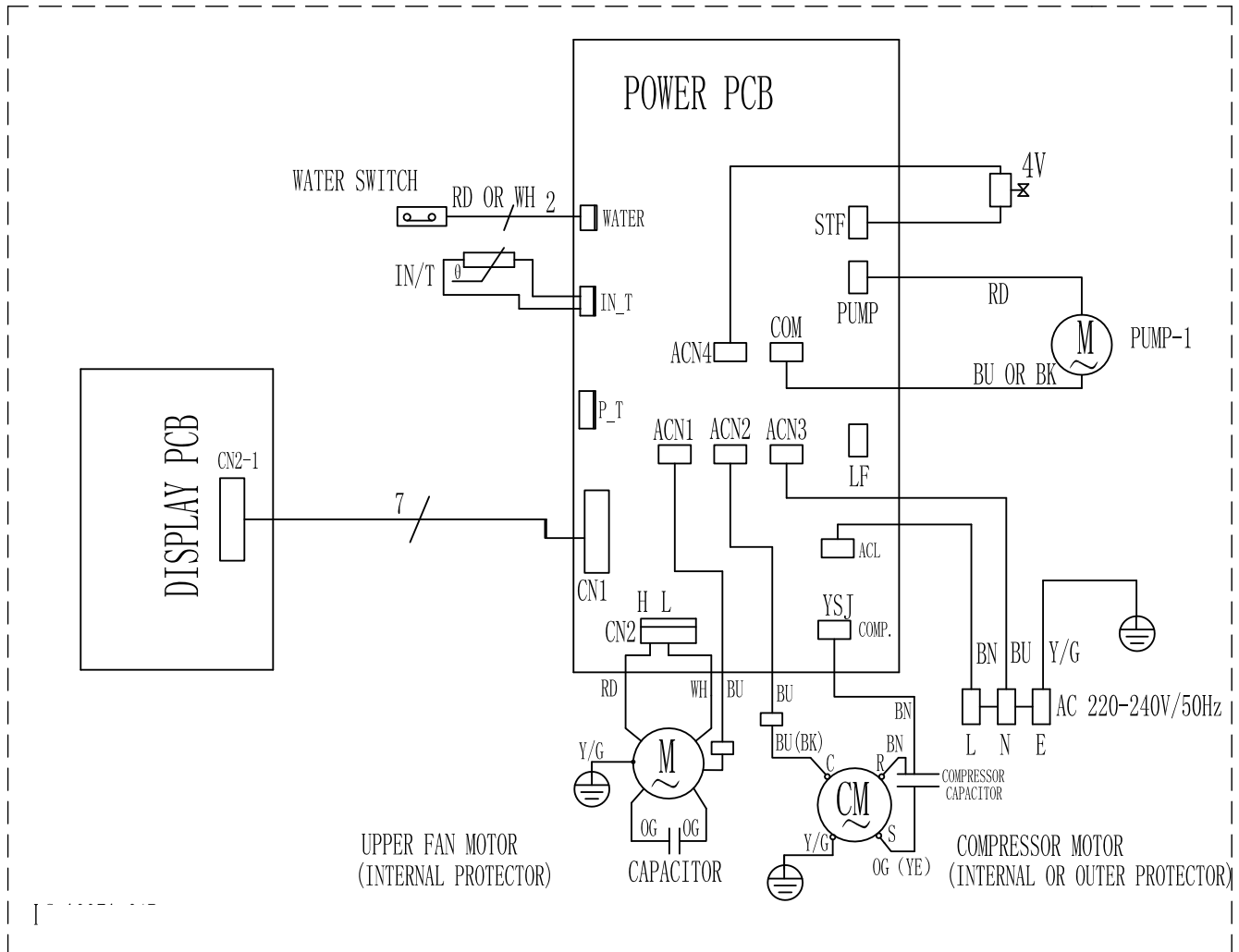

Overview and lists of spare parts

Note: The position numbers of the spare parts differ from those describing the positions of other parts mentioned in this operating manual.

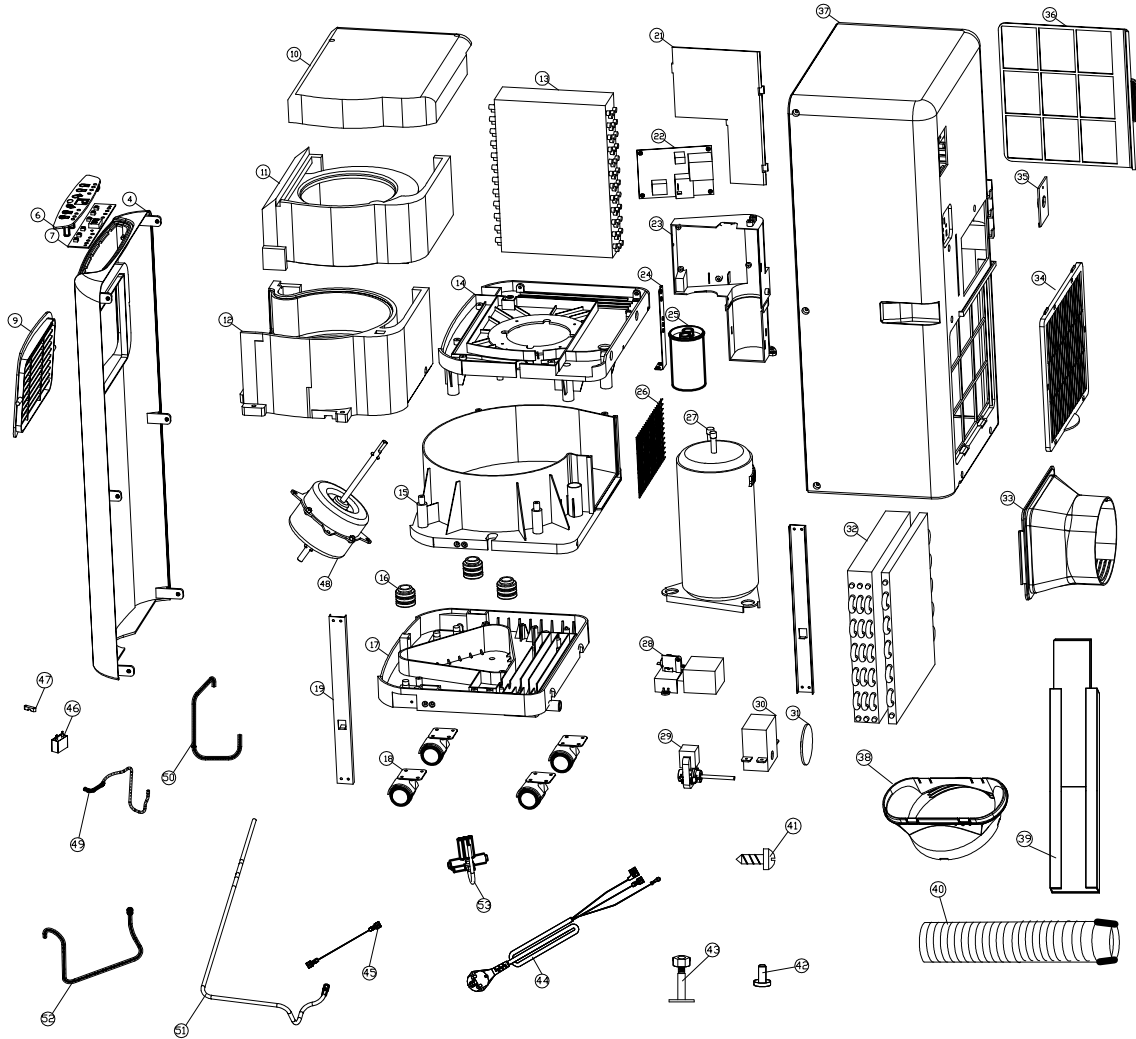

| No. | Part Name | No. | Part Name | No. | Part Name |
|-----|---------------------------|-----|---------------------------------|-----|-----------------------|
| 4 | front panel | 23 | pc board box | 39 | window kit |
| 6 | control panel | 24 | pc board support bar | 40 | flexible exhaust hose |
| 7 | display PCB | 25 | compressor capacitor | 41 | screw |
| 9 | venting frame | 26 | wire netting | 42 | stopper |
| 10 | top foam | 27 | compressor | 43 | bolt (with nut) |
| 11 | updraft duct foam | 28 | micro switch | 44 | power cord |
| 12 | downdraft duct foam | 29 | shaded pole motor | 45 | wiring |
| 13 | evaporator | 30 | shaded pole motor box | 46 | motor capacitor |
| 14 | scroll casing cover board | 31 | pump wheel | 47 | cord grip |
| 15 | scroll casing pedestal | 32 | condenser | 48 | motor |
| 16 | compressor rubber pad | 33 | flexible exhaust hose connector | 49 | high-voltage tube-2 |
| 17 | under pan | 34 | grating cover | 50 | high-voltage tube-1 |
| 18 | flexible wheel | 35 | bore cover of power cord | 51 | low-voltage tube-2 |
| 19 | support bar | 36 | dust screen | 52 | low-voltage tube-1 |
| 21 | pc board cover board | 37 | back panel | 53 | four-way valve |
| 22 | power panel | 38 | exhaust adapter | | |

Disposal



The icon with the crossed-out waste bin on waste electrical or electronic equipment stipulates that this equipment must not be disposed of with the household waste at the end of its life. You will find collection points for free return of waste electrical and electronic equipment in your vicinity. The addresses can be obtained from your municipality or local administration. For further return options provided by us please refer to our website www.trotec24.com.

The separate collection of waste electrical and electronic equipment aims to enable the re-use, recycling and other forms of recovery of waste equipment as well as to prevent negative effects for the environment and human health caused by the disposal of hazardous substances potentially contained in the equipment.

Have the refrigerant (propane) disposed of appropriately and according to the national regulations by a company with the relevant certification (European Waste Catalogue 160504).



In the European Union, batteries and accumulators must not be treated as domestic waste, but must be disposed of professionally in accordance with Directive 2006/66/EC of the European Parliament and of the Council of 6 September 2006 on batteries and accumulators. Please dispose of batteries and accumulators according to the relevant legal requirements.

Trotec GmbH

Grebener Str. 7
D-52525 Heinsberg

☎ +49 2452 962-400

☎ +49 2452 962-200

✉ info@trotec.com

www.trotec.com